

water technicians



2024

ROBERTO BRUNA
NOZZLES



USER'S MANUAL



Handling of high-pressure water equipment may be dangerous.

Breaches of safety instructions and recommended practices may provoke serious injuries or even death.

- Do not exceed the maximum pressure specified for any system component.
- Delimit the work area in order to keep unqualified people away from it.
- Check and inspect all equipment before starting work. Verify that there are no visible damages, signs of deterioration or incorrect assembly. If the equipment is damaged do not use it until it has been repaired.
- Make sure that all the connections and threads are tightened and that they do not have any leak.
- When carrying out maintenance or replacing any piece, before opening any part, make sure all equipment is properly turned off, otherwise, you may suffer serious injuries or even death.

Safety check prior start-up

- Mechanical stops, rigid nipples and recoil inhibitors should be installed accordingly when carrying out the cleaning of any pipeline, tube or container.
- Complete a job specific risk assessment and act accordingly with appropriate measures.
- Make sure that the area to be sprayed with high-pressure water is properly fenced and that warning signs have been placed.
- Make sure the work area is kept clutter-free at all times (for example: loose pieces, hoses or work tools).
- Make sure that all the operators are properly equipped with Personal Protective Equipment (PPE).
- High-pressure water must only be applied using high-quality hoses.
- Verify that all connections are thoroughly tightened.
- Make sure that operators do not connect, disconnect or adjust hoses, nozzles and accessories when the equipment is on.
- Make sure that all staff members are clear from the area where high-pressure water is to be applied.

Personal Protective Equipment (PPE)

The use of the Personal Protective Equipment (PPE) depends on the pressure that is to be applied and on the type of cleaning to be performed.

Managers, supervisors and operators must carry out a specific risk assessment for every assignment to define exact PPE requirements.

- First aids: it is MANDATORY to have adequate on-site first aids facilities available for the users.

The PPE may include:

- Ocular protection: complete protective visor.
- Feet protection: impermeable and non-slipping boots with steel toe cap
- Hands protection: impermeable gloves.
- Hearing protection: hearing protection equipment for at least 85 dba.
- Protective headgear : a rigid helmet compatible with the visor and the hearing protection.
- Body protection: approved impermeable multi-layer clothes for high-pressure water use.
- Hose protection: hose cover.
- Respiratory protection: it may be required. Check the section of specific risk assessment for each job type.

Roberto Bruña, S.L. designs and manufactures all its nozzles and accessories bearing in mind all the risks associated with their use and functioning.

These risks were studied and evaluated by Roberto Bruña, S.L. technical team and important safety characteristics were incorporated into the design.

Roberto Bruña, S.L. will NOT accept any responsibility for the results of the inadequate use of the equipment.

It is the sole responsibility of the installer / operator to carry out a specific risk assessment for every project before using the equipment. An appropriate risk assessment must be performed again before every new project.



GRENADAES

SAND & STONES







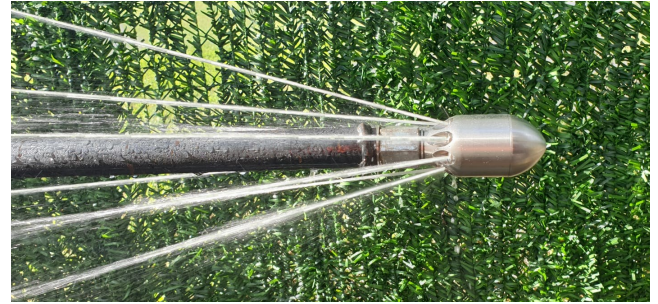

GRENADE 50

· SEWER & DRAIN CLEANING ·



8 JETS



	Thread	1/2"
	Pipe diameter	125 - 300 MM
	Rear jets	8 JETS AT 7° AND 15°
	Water Flow (l/min)	FROM 40 L/M
	Measures (mm)	50 X 95 MM
	Weight	750 GR







GRENADE 60

· SEWER & DRAIN CLEANING ·



30°-10°
SIX JETS



	Thread	3/4" - 1"
	Pipe diameter	200 - 300 MM
	Rear jets	3 AT 30° AND 3 AT 10°
	Water Flow (l/min)	160 TO 300 L/M
	Measures (mm)	60 X 110 MM
	Weight	1.3 KG

GRENADE 60 BULLET

· SEWER & DRAIN CLEANING ·
PROPULSION AND FORWARD



6 JETS AT 10°



GRENADE 70









12 JETS



· SAND REMOVAL ·



	Thread	3/4" - 1"
	Pipe diameter	200 - 400 MM
	Rear jets	12 JETS // 7°—14°—21°
	Water Flow (l/min)	160 TO 300 L/M
	Measures (mm)	70 X 125 MM
	Weight	2 KG

GRENADE 80









10 JETS



· SEWER & DRAIN CLEANING ·









	Thread	3/4" - 1"
	Pipe diameter	250 - 500 MM
	Rear jets	5 AT 30° AND 5 AT 10°
	Water Flow (l/min)	160 TO 400 L/M
	Measures (mm)	80 X 170 MM
	Weight	4 KG

GRENADE 100



10 JETS









	Thread	3/4" - 1"
	Pipe diameter	300 - 600 MM
	Rear jets	5 AT 7° & 5 AT 15°
	Water Flow (l/min)	200 TO 300 L/M
	ØxL Measures (mm)	100 X 177 MM
	Weight	4.5 KG

GRENADE 120



15 JETS



	Thread	1"-1/4" & 1"
	Pipe diameter	300 - 800 MM
	Rear jets	15 JETS // 7°-15°-20°
	Water Flow (l/min)	200 TO 300 L/M
	ØxL Measures (mm)	120 X 200 MM
	Weight	10 KG

FLOUNDERS

DRAGGING & CLEANING





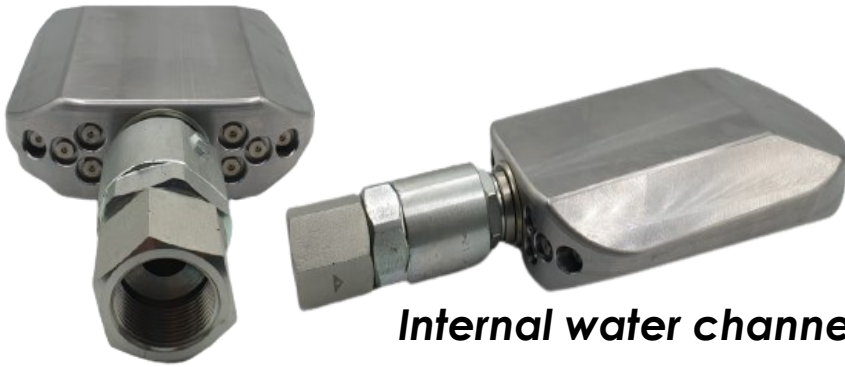



FLOUNDER 1"



Internal water channeling system







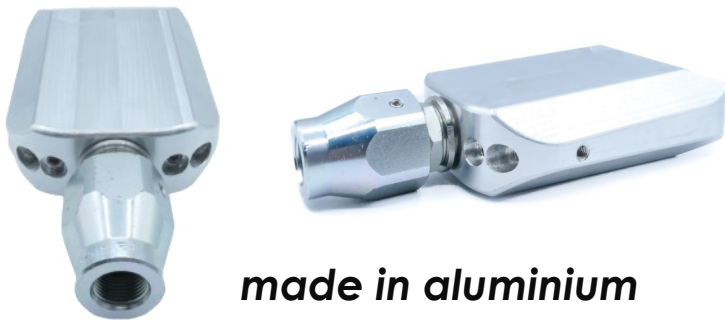

	Thread	1"
	Pipe diameter	350 -700 MM
	Rear jets	4 AT 5° & 4 AT 10°
	Water Flow (l/min)	FROM 200 L/M
	Measures (mm)	145 x 225 MM
	Weight	9 KG

LIGHT FLOUNDER 1/2"









made in aluminium

	Thread	1/2"
	Pipe diameter	125 -400 MM
	Rear jets	4 AT 5°
	Water Flow (l/min)	FROM 40 L/M
	Measures (mm)	90 x 150 MM
	Weight	1.3 KG

FLOUNDER 1/2"



	Thread	1/2"
	Pipe diameter	125 -400 MM
	Rear jets	4 AT 5°
	Water Flow (l/min)	FROM 80 L/M
	Measures (mm)	90 x 150 MM
	Weight	3.2 KG

OPTIONAL SWIVEL THREADS

FLOUNDERS 1/2"

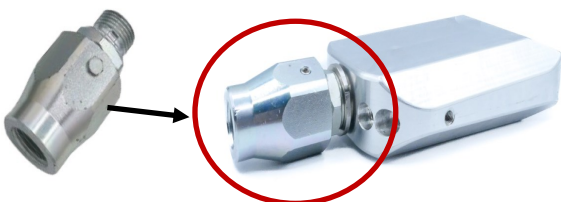

FLOUNDER 1"

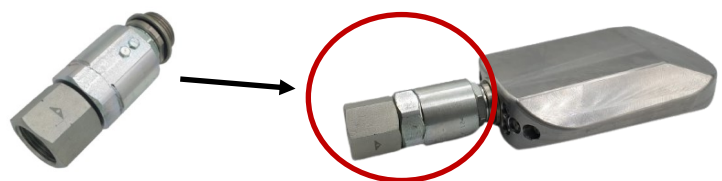

BREAKERS & ALLIENS

WATER BLASTING



ALLIEN RANGE

· ROTARY FRONTAL JET ·









· SIMPLE MECHANISM ·



Applications: – Blocked pipelines, root masses, frozen systems.

BREAKER 1/2









 Thread	1/2"
 Pipe diameter	75-200 MM
 Rear Jets	3 FRONTAL AND 3 REAR
 Water Flow (l/min)	FROM 40 L/M
 ØxL Measures (mm)	40 X 50 MM
 Weight	200 GR









BREAKER 1"



 Thread	3/4" - 1"
 Pipe diameter	200-500 MM
 Rear Jets	3 FRONTAL AND 6 REAR 25°
 Water Flow (l/min)	FROM 160 L/M
 ØxL Measures (mm)	50 X 90 MM
 Weigh	650 GR

ALLIEN 1/4"







	Thread	1/4"
	Pipe diameter	75 - 160 MM
	Rear Jets	3 DRILLED JETS
	Water Flow (l/min)	FROM 40 L/M
	Measures (mm)	23 X 40 MM
	Weight	133 GR



ALLIEN 1/2"









**ITS SMALL SIZE MAKES IT PERFECT
FOR USE IN ELBOW JOINTS**

	Thread	1/2"
	Pipe diameter	90 - 160 MM
	Rear Jets	6 AT 15°
	Water Flow (l/min)	FROM 40 L/M
	Measures (mm)	32 X 56 MM
	Weight	170 GR







ALLIEN 1/2" TURBO

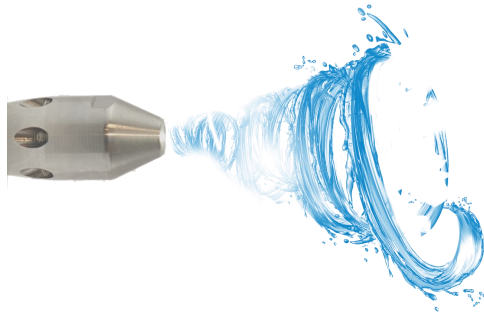

	Thread	1/2"
	Pipe diameter	125 - 300 MM
	Rear jets	3 AT 7°
	Water Flow (l/min)	FROM 40 L/M
	Measures (mm)	45 X 125 MM
	Weight	905 GR







ALLIEN 3/4"



	Thread	3/4"
	Pipe diameter	200 - 400 MM
	Rear jets	6 JETS AT 30°
	Water Flow (l/min)	100 TO 300 L/M
	Measures (mm)	38 X 75 MM
	Weight	349 GR

ALLIEN 1"



	Thread	1"
	Pipe diameter	200 - 500 MM
	Rear jets	3 AT 30° AND 3 AT 10°
	Water Flow (l/min)	160 TO 300 L/M
	Measures (mm)	60 X 134 MM
	Weight	1.4 KG

TARANTULAS

FOR HARD WORKS









TARANTULA 1"

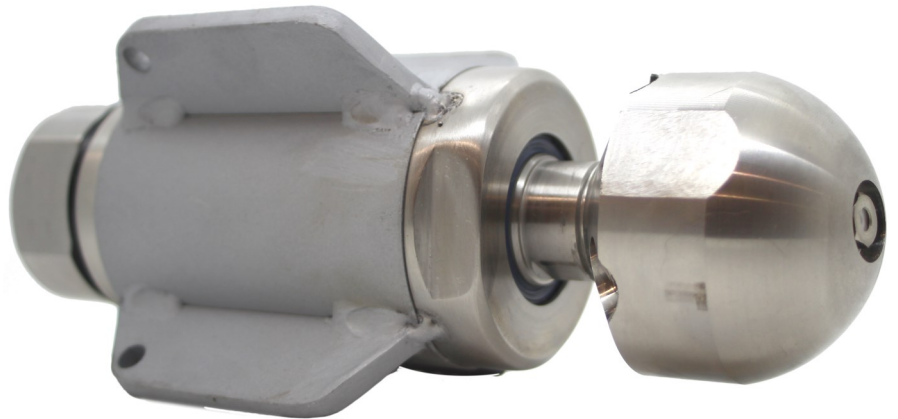
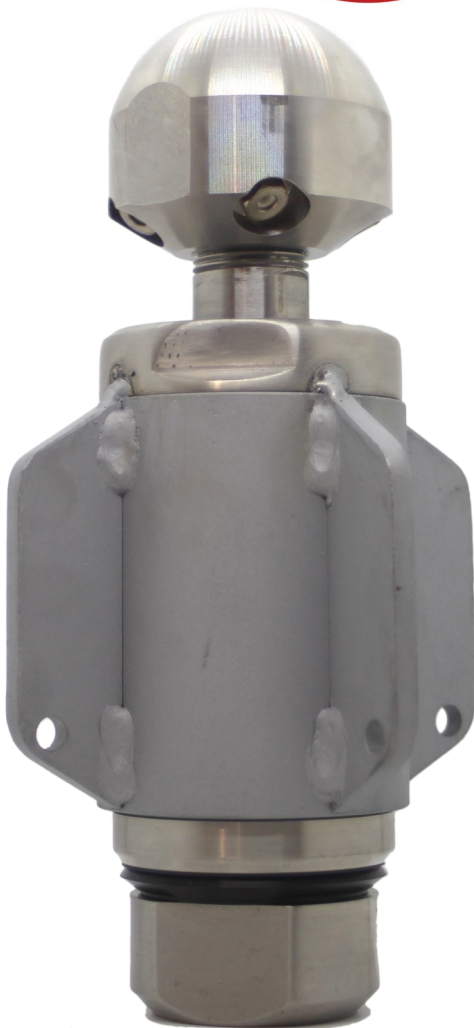

SLOW ROTATION

Applications: – Difficult jobs, hard remains, soaps, small roots...



	Thread	1" - 3/4"
	Pipe diameter	300 - 600 MM
	Rear jets	2 JETS AT 30°
	Water Flow (l/min)	215 TO 315 L/M
	Measures (mm)	120 X 230 MM
	Weight	4.5 KG

TARANTULA 3/4"







· HARD JOBS ·

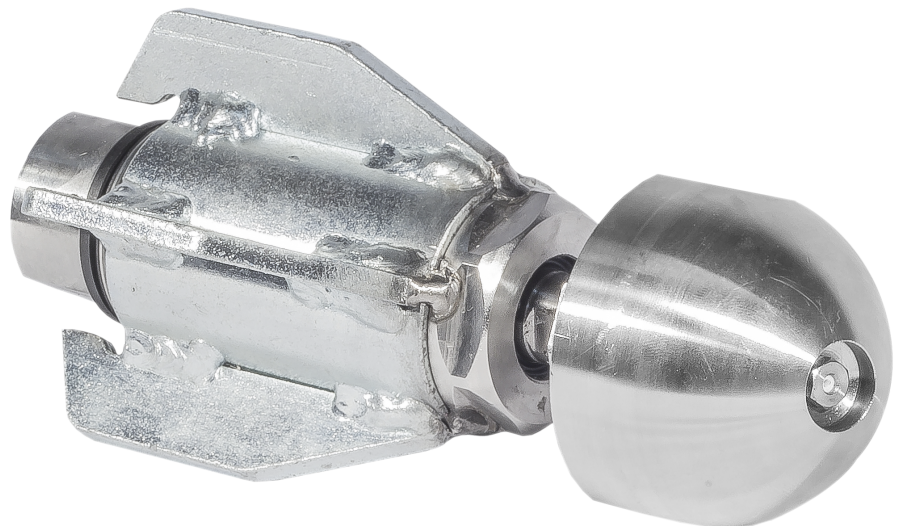

SLOW ROTATION

Applications: – Difficult jobs, hard remains, soaps, small roots...



	Thread	3/4"
	Pipe diameter	250 - 400 MM
	Rear jets	2 JETS AT 25°
	Water Flow (l/min)	100 TO 215 L/M
	Measures (mm)	86 X 190 MM
	Weight	2.2 KG









Applications: – Difficult jobs, hard remains, soaps, small roots...

With an oil regulation system to extend the life of the nozzle and significantly delay its maintenance.



· SLOW ROTATION ·

	Thread	1/2"
	Pipe diameter	125-300 MM
	Rear jets	2 JETS
	Water Flow (l/min)	FROM 80 L/M
	Measures (mm)	48 X 120 MM
	Weight	1.02 KG

TARANTULA 1/2" SELF-REGULATING







USE:- Hard work, solid residues, soaps.

Forget about maintenance for a long time.

This model has a long service life thanks to the additional adjustable oil reservoir.



• SLOW ROTATION •







	Thread	1/2"
	Pipe diameter	110 - 250 MM
	Rear jets	2 JETS
	Waterflow (l/min)	FROM 40 L/M
	Measures (mm)	38 X 93 MM
	Weight	485 GR



TARANTULA 1/2"



• SLOW ROTATION •

	Thread	1/2"
	Pipe diameter	110 - 250 MM
	Rear jets	2 JETS
	Water Flow (l/min)	FROM 40 TO 215 L/M
	Measures (mm)	37 X 85 MM
	Weight	360 GR



TARANTULA 3/8"







· HARD JOBS ·



SLOW ROTATION

Applications: – Difficult jobs, hard remains, soaps, small roots, hard jobs in tanks...



	Thread	3/8"
	Pipe diameter	75-200 MM
	Rear jets	2 JETS
	Water Flow (l/min)	FROM 40 L/M
	Measures (mm)	28 X 65 MM
	Weight	200 GR







TARANTULA 1/4"

· HARD JOBS ·

Applications: – Difficult jobs, hard remains, soaps, small roots, hard jobs in tanks...

SLOW ROTATION



	Thread	1/4"
	Pipe diameter	75-160 MM
	Rear jets	2 JETS
	Water Flow (l/min)	FROM 40 L/M
	Measures (mm)	28 X 62 MM
	Weight	190 GR

SPECIFIC WORKS NOZZLES

FOR TECHNICAL WORKS

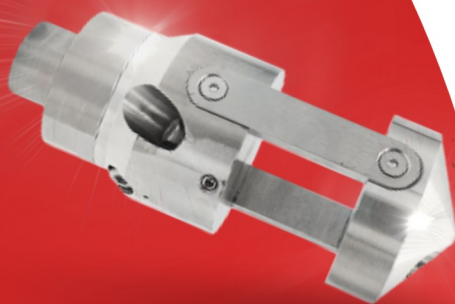
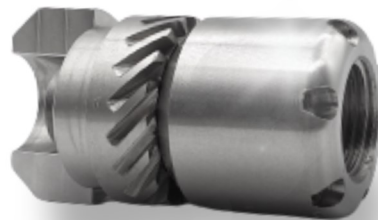
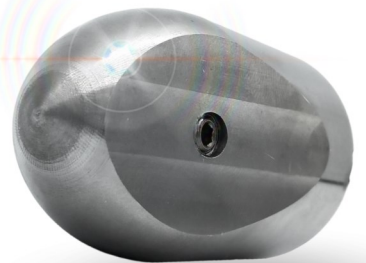







ROOT CUTTER NOZZLES

Applications: Eliminate hard-to-reach roots

ROOT CUTTER 1/2"

ROOT CUTTER FOR SCRAPING
AROUND THE PIPE







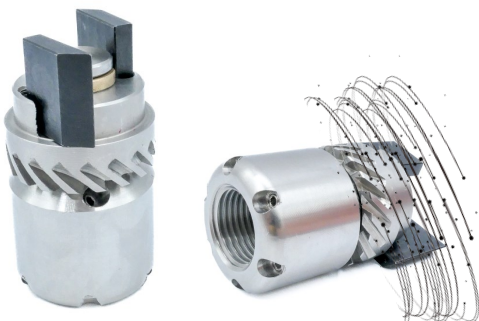

	Thread	1/2"
	Pipe diameter	90 -200 MM
	Rear jets	6 JETS
	Water Flow (l/min)	FROM 40 L/M
	Measures (mm)	35 X 64 MM
	Weight	285 GR

ROOT CUTTER 1/4"

ROOT CUTTER FOR SCRAPING
AROUND THE PIPE







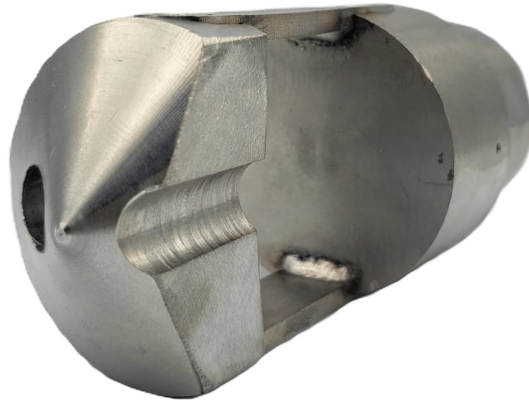

	Thread	1/4"
	Pipe diameter	50-160 MM
	Rear jets	6 JETS
	Water Flow (l/min)	FROM 40 L/M
	Measures (mm)	28 X 51 MM
	Weight	160 GR

·VIBRATING NOZZLES ·

Applications: Powerful vibration nozzle ideal for hard jobs, such as pipes with cement, concrete and solidified lime residues







HEAVY 1/2"



	Thread	1/2"
	Pipe diameter	160 MM
	Rear jets	6 JETS
	Water Flow (l/min)	FROM 40 L/M
	Measures (mm)	55 X 140 MM
	Weight	1.2 KG







LIGHT 1/2"



	Thread	1/2"
	Pipe diameter	90 MM
	Rear jets	6 JETS
	Water Flow (l/min)	FROM 40 L/M
	Measures (mm)	35 X 70 MM
	Weight	330 GR

MINI 1/4"



	Thread	1/4"
	Pipe diameter	50 MM
	Rear jets	6 JETS
	Water Flow (l/min)	-
	Measures (mm)	28 X 50 MM
	Weight	160 GR







• WIPE CATCHER NOZZLES •

WIPE CATCHER 1/2"



BASIC MODEL: Hooks catch wiper when pulling back the hose







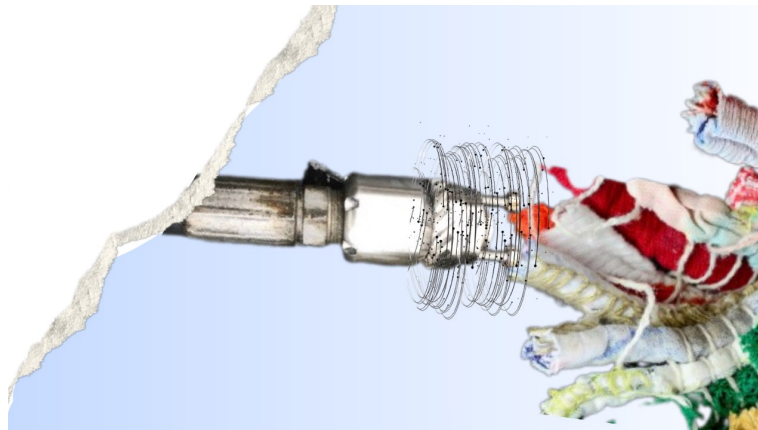

	Thread	1/2"
	Pipe Diameter	75-200 MM
	Rear Jets	6 JETS AT 15°
	Water Flow (l/min)	FROM 40 L/M
	Measures (mm)	30 X 50 MM
	Weight	100 GR

ROTATION MODEL:
The wipes are caught by
the rotating turbine









ROTATIONAL WIPE CATCHER 1/2"



	Thread	1/2"
	Pipe diameter	75 –200 MM
	Rear jets	6 JETS AT 7°
	Water Flow (l/min)	FROM 40 L/M
	Measures (mm)	35 X 64 MM
	Weight	300 GR

ROTATIONAL WIPE CATCHER 1/4"







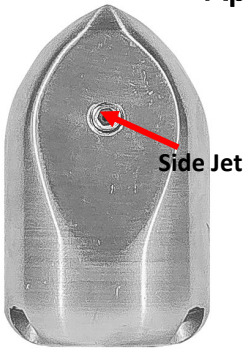

	Thread	1/4"
	Pipe diameter	50-160 MM
	Rear jets	6 JETS AT 7°
	Water Flow (l/min)	FROM 40 L/M
	Measures (mm)	28 X 58 MM
	Weight	150 GR

ANACONDA 1/2" CATCHPITS

The side jet pushes the nozzle to one side of the catchpit or pipe, in order to get access to the pipelines that are not accessible.

Applications: Cleaning of branches and pipe connections.



	Thread	1/2"
	Pipe Diameter	110 - 200 MM
	Rear Jets	3 AT 15° + LATERAL
	Water Flow (l/min)	FROM 40 L/M
	Measures (mm)	40 X 65 MM
	Weight	380 GR

LATERAL CONNECTION

LATERAL CONNECTION

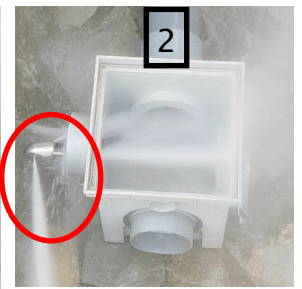
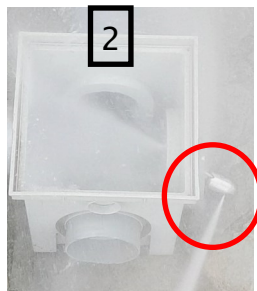







ANACONDA 1/2" (LITTLE)



Lateral Jet









	Thread	1/2"
	Pipe Diameter	75 - 160 MM
	Rear Jets	6 AT 15° + LATERAL
	Water Flow (l/min)	FROM 40 L/M
	Measures (mm)	34 X 31 MM
	Weight	110 GR

ANACONDA 3/8"







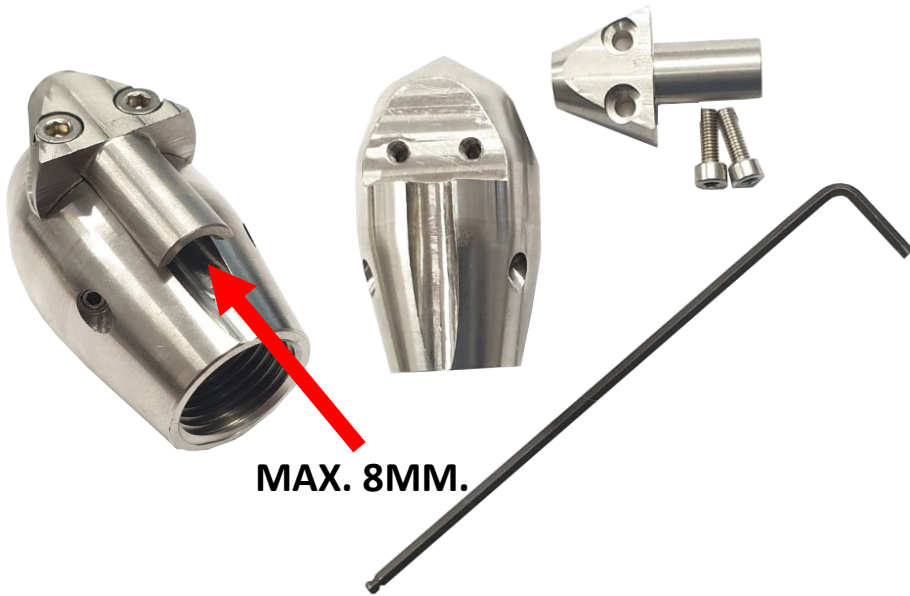

Lateral Jet

	Thread	3/8"
	Pipe Diameter	90 - 160 MM
	Rear Jets	4 AT 15° + LATERAL
	Water Flow (l/min)	FROM 30 L/M
	Measures (mm)	30 X 37 MM
	Weight	112 GR

CAMERA NOZZLE 1/2"

Applications: – Nozzle for pushing and handling the head of the manual pipe inspection camera. The fiber cable slides through the nozzle.









	Thread	1/2"
	Pipe Diameter	110 - 250 MM
	Rear Jets	3 JETS AT 15°
	Water Flow (l/min)	FROM 40 L/M
	Measures (mm)	39 X 60 MM
	Weight	260 GR

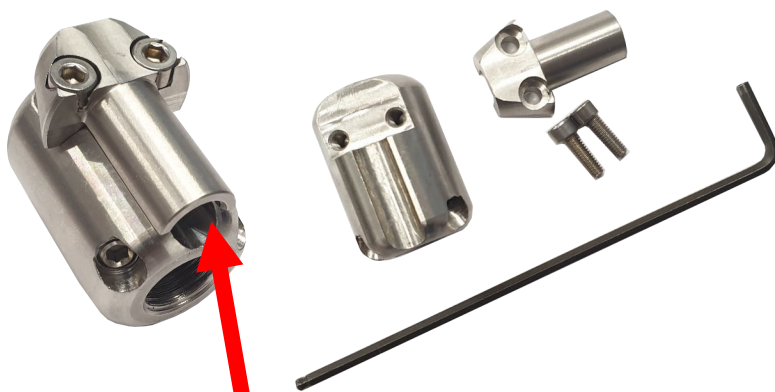

CAMERA NOZZLE 1/4"

Applications: – Nozzle for pushing and handling the head of the manual pipe inspection camera. The fiber cable slides through the nozzle.



	Thread	1/4"
	Pipe Diameter	75 - 200 MM
	Rear Jets	3 JETS AT 15°
	Water Flow (l/min)	FROM 40 L/M
	Measures (mm)	32 X 39 MM
	Weight	135 GR



COMMON NOZZLES





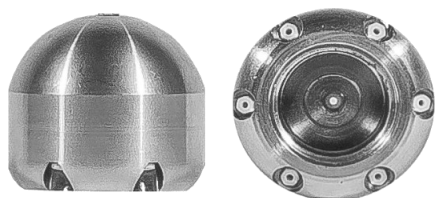

· ALL TIME BASICS ·

BUTTON 1/2"

.- Applications: cleaning // unblocking









(The smallest in 1/2")

 Thread	1/2"
 Pipe Diameter	75 - 160 MM
 Rear Jets	6 AT 7°
 Water Flow (l/min)	FROM 40 L/M
 ØxL Measures (mm)	34 X 31 MM
 Weight	100 GR

MIXED BUTTON 1/2 "

- Applications: cleaning // unblocking









 Thread	1/2"
 Pipe Diameter	75 - 160 MM
 Rear Jets	3 AT 7° AND 3 AT 15°
 Water Flow (l/min)	FROM 40 L/M
 ØxL Measures (mm)	34 X 31 MM
 Weight	100 GR

12 JETS

- Applications: cleaning // unblocking









 Thread	1/2"
 Pipe Diameter	100 - 200 MM
 Rear Jets	12 JETS AT 7°
 Water Flow (l/min)	FROM 100 L/M
 ØxL Measures (mm)	35 X 31 MM
 Weight	100 GR

7° & 30° NOZZLE

UNBLOCKING TG 7°:



	Thread	1/2"
	Pipe Diameter	100 - 200 MM
	Rear Jets	6 JETS
	Water Flow (l/min)	FROM 40 L/M
	ØxL Measures (mm)	40 X 53 MM
	Weight	280 GR







CLEANING TG 30°



TIGER 3/8"

- Applications: - Unblocking pipes







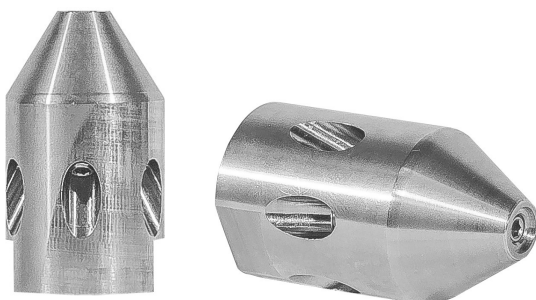

	Thread	3/8"
	Pipe Diameter	90 -160 MM
	Rear Jets	4 JETS (Frontal Optional)
	Water Flow (l/min)	FROM 30 L/M
	ØxL Measures (mm)	30 X 37 MM
	Weight	125 GR

VAMPIRE

The "vampire" nozzle has rear jets at 35°

- Applications: - Cleaning pipes









	1/2	3/4"	1"
	160-200 MM	200 - 300 MM	250 - 400 MM
	6 JETS	6 JETS	8 JETS
	FROM 40 L/M	FROM 120 L/M	FROM 180 L/M
	30 X 53 MM	35 X 61 MM	50 X 70 MM
	150 GR	230 GR	560 GR

BULLET 1/2"

MAXIMUM ADVANCE

-The best choice for long distances and strong unblocking.

Applications: - Unblocking pipes







 Thread	1/2"
 Pipe Diameter	110 - 250 MM
 Rear Jets	3 JETS OR 6 JETS
 Water Flow (l/min)	FROM 40 L/M
 Measures (mm)	47 X 82 MM
 Weight	600 GR



LINX 1/2"

- Applications: - Cleaning pipes









 Thread	1/2"
 Pipe Diameter	160 - 300 MM
 Rear Jets	3 JETS AT 25°
 Water Flow (l/min)	FROM 40 L/M
 Measures (mm)	64 X 115 MM
 Weight	600 GR

BASIC 3/4"

- Applications: - Unblocking pipes

- Useful and low-cost nozzle.



 Thread	3/4"
 Pipe Diameter	160 - 300 MM
 Rear Jets	6 AT 15°
 Water Flow (l/min)	FROM 160 L/M
 Measures (mm)	50 X 67 MM
 Weight	430 GR

STOPPER

· UNBLOCKING 32-75mm ·

How to use it: the pipe is plugged with a plastic plug sealing it tightly.

- Make sure that there are no branches or that they are properly plugged.

If you tighten the rubber, it enlarges, adapting to the tube.



It allows water to flow

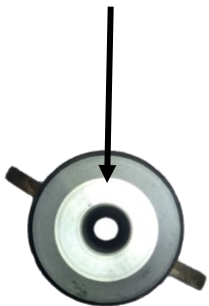

RUBBER RINGS FROM 40 TO 50 FOR DIFFERENT SIZES



1º



2º



HOSE

1/4" HOSE AND
1/8" THREAD

10 METERS

15 METERS







20 METERS



1/8" SIX JETS



CERAMIC JETS

 Thread	1/8"
 Pipe Diameter	50-110 MM
 Rear Jets	6 CERAMIC JETS
 Water flow (l/min)	FROM 30 L/M
 Measures (mm)	17 X 20 MM
 Weight	15 GR

SLEEVE

1/8" THREAD

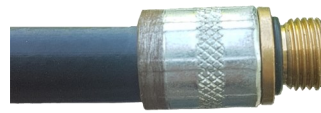

REEL FOR HOSE



1/2" Conexion





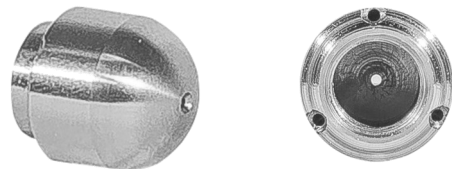

Nozzle holder

MEASURES (MM): 300 X 300 X 300

WEIGHT: 4 KG

NOZZLE 1/8" TURBO







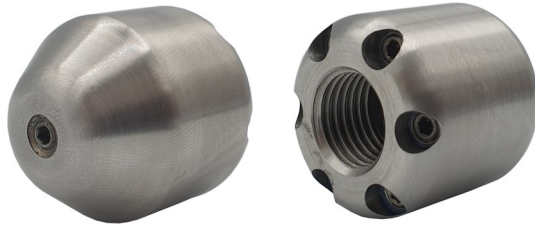

 Thread	1/8"
 Pipe Diameter	40 -75 MM
 Rear Jets	3 DRILLED JETS
 Water flow (l/min)	FROM 30 L/M
 Measures (mm)	16 X 17 MM
 Weight	15 GR

· SMALL NOZZLES ·

TIGER 1/4

DRAG AND CLEANING







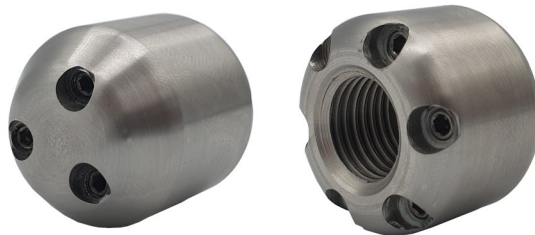

	Thread	1/4"
	Pipe Diameter	75– 160 MM
	Rear Jets	6 JETS
	Water Flow (l/min)	FROM 40 L/M
	Measures (mm)	25 X 33 MM
	Weight	60 GR

BREAKER 1/4 "

UNBLOCK







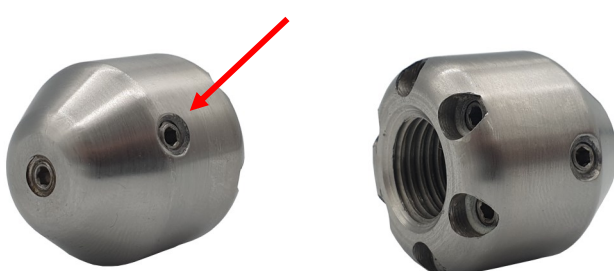

	Thread	1/4"
	Pipe Diameter	75– 160 MM
	Rear Jets	6 JETS
	Water Flow (l/min)	FROM 40 L/M
	Measures (mm)	25 X 33 MM
	Weight	70 GR

ANACONDA 1/4 "

Lateral jet









	Thread	1/4"
	Pipe Diameter	75– 160 MM
	Rear Jets	6 JETS
	Water Flow (l/min)	FROM 40 L/M
	Measures (mm)	25 X 33 MM
	Weight	60 GR

1/4" BASIC NOZZLE



· DRAINAGE ·







	Thread	1/4"
	Pipe Diameter	50- 110 MM
	Rear Jets	6 JETS
	Water Flow (l/min)	FROM 30 L/M
	ØxL Measures (mm)	18 X 20 MM
	Weight	20 GR

BRUNA 1/4"

Front jet optional









· DRILLED ·

	Thread	1/4"
	Pipe diameter	50- 110 MM
	Rear jets	6 JETS 15°
	Water Flow (l/min)	FROM 30 L/M
	ØxL Measures (mm)	21 X 24 MM
	Weight	40 GR

BRUNA 1/2"

Front jet optional



	Thread	1/4"
	Pipe diameter	90 - 200 MM
	Rear jets	6 JETS 20°
	Water Flow (l/min)	FROM 40 L/M
	ØxL Measures (mm)	35 X 40 MM
	Weight	50 GR

VENTURY & GUIDE BAR

For water suction.

Optional water guide extension bar for increased suction without interrupting the water jet.



	VENTURY	BAR
Thread		1/2"
Waterflow (l/min)		FROM 40 L/M
Measures (mm)	100 x 180 MM	50 X 235 MM
Weight	700 GR	850 GR



ANTI-RETURN BAR

Bar to be placed between hose and nozzle

	1"	3/4"	1/2"
THREAD	1"	3/4"	1/2"
WEIGHT	753 GR	568 GR	218 GR
MEASURES	230 x 48 MM	240 X 44 MM	126 x 28 MM



TANK CLEANING NOZZLE

Nozzle with a slow rotation head, perfect to clean the walls of wells or tanks.

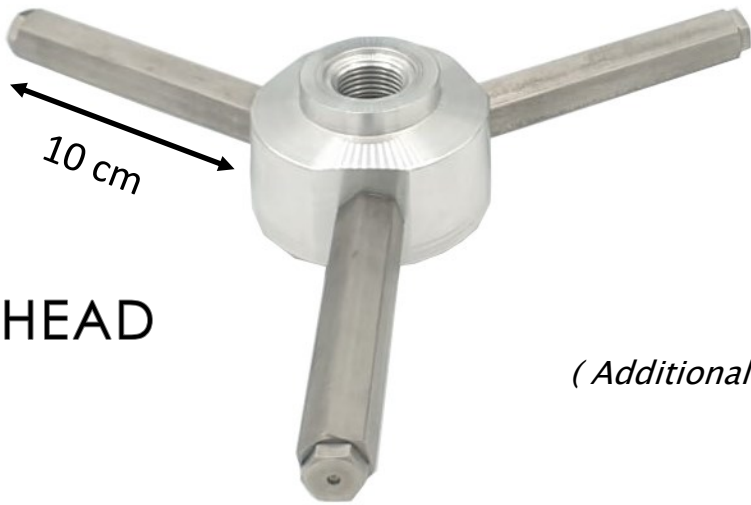

HEAD

(Additional extension bars 3pack available)

Possible to connect to hose directly



1/2"

Weight: 1.7 KG

Measures(mm): 27 x 15 MM



3/4"

Weight: 2.4 KG

Measures (mm): 27 x 19 MM



1"

Weight: 4.7KG

Measures (mm): 27 x 25 MM

CATCHPITS LIFTER

Technical Characteristics







- Stainless Steel
- Diameter of the magnet: 100 MM
- Grip strenght approx: 400 KG.
- Weight: 3.7 KG
- Protective Case included



TURBOROTATING

- Ideal for washing surfaces.
- Powerful rotating jet



	Thread	1/4" (ADAPTABLE ANY SIZE)
	Pipe Diameter	ANY
	Rear Jet	-
	Water Flow (l/min)	-
	Measures (mm)	34 X 79 MM
	Weight	350 GR



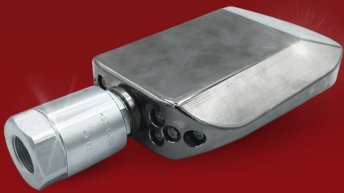
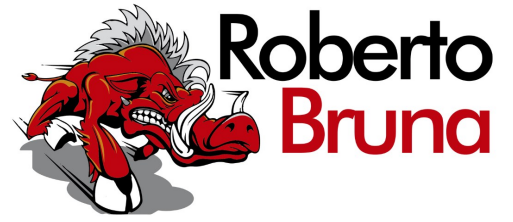

ROBERTO BRUNA S.L.
+(44) 7751 8808 88
sales@robertobruna.com

Recta de Heras 7
39619 San Salvador
Cantabria, Spain

2024